

# NemaTRUE™

## True Planetary Gearheads

Ready for Immediate Delivery	
Precision	13 arc-minutes
Frame Sizes	17, 23/60 mm, 34/90 mm and 42/115 mm
Torque Capacity	up to 180 Nm
Ratio Availability	3:1 thru 100:1
Radial load capacity	up to 3730 N
Mounting System	RediMount™

- 1 Sealed deep groove ball bearings**  
provide high radial load carrying capability
- 2 HRC 55-60 steel gears**  
provide superior wear resistance  
and increased backlash integrity
- 3 Sealed deep groove ball bearing**  
provides precision alignment of sun gear
- 4 RediMount system**  
provides error-free motor installation
- 5 Anodized aluminum housing**  
reduces weight and prevents corrosion

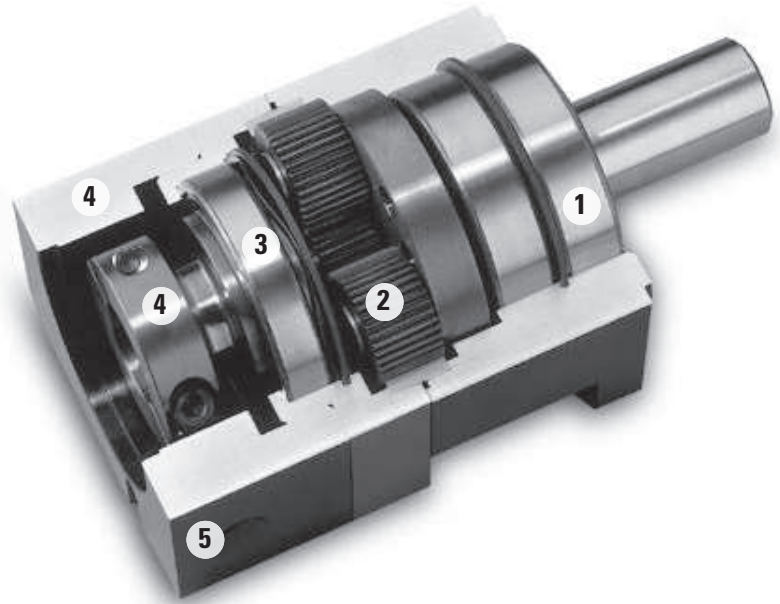

**Micron True™ Planetary Gearheads  
shipped within 24 hours!**



**Need it fast? Go to the back cover  
of the catalog for details.**

# NemaTRUE Size 17

## True Planetary Gearheads

English

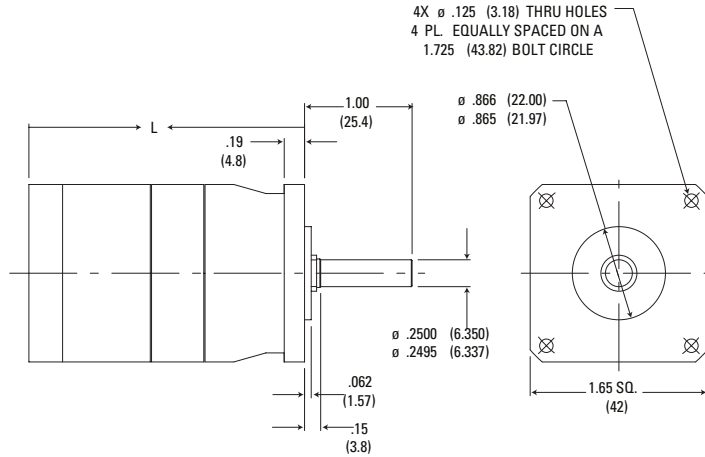

Ratio <sup>1</sup>	Dimension 'L' in. [mm]	Backlash [arc-min]	Weight lb. [kg]	Efficiency
3:1 to 10:1	2.28 [58]	13 max	.75 [0,34]	93%
15:1 to 100:1	2.77 [71]	15 max	.95 [0,43]	88%

Dimensions are inch (mm)  
Efficiency is calculated at 100% of the rated torque.  
Total length may change depending on motor being used.

## Performance Specifications

Part Number	Ratio <sup>1</sup>	20000 Hour Life				T <sub>peak</sub> in.-lb. [Nm]	J in.-lb.-sec <sup>2</sup> x10 <sup>-4</sup> [kg-cm <sup>2</sup> ]	Torsional Stiffness in.-lb./arc-min [Nm/arc-min]
		T <sub>r</sub> (1000 rpm) in.-lb. [Nm]	T <sub>r</sub> (2000 rpm) in.-lb. [Nm]	T <sub>r</sub> (3000 rpm) in.-lb. [Nm]	T <sub>r</sub> (4000 rpm) in.-lb. [Nm]			
NT17-003	3:1	41 [4,7]	34 [3,8]	29 [3,3]	27 [3,1]	170 [19,2]	0.115 [0,013]	2.36 [0,268]
NT17-005	5:1	44 [5,0]	37 [4,2]	33 [3,7]	30 [3,4]	170 [19,2]	0.040 [0,005]	2.36 [0,268]
NT17-010	10:1	30 [3,4]	28 [3,1]	25 [2,8]	23 [2,6]	170 [19,2]	0.030 [0,003]	2.36 [0,268]
NT17-015	15:1	47 [5,3]	47 [5,3]	47 [5,3]	42 [4,7]	170 [19,2]	0.037 [0,004]	2.36 [0,268]
NT17-025	25:1	78 [8,8]	58 [6,6]	53 [6,0]	48 [5,5]	170 [19,2]	0.037 [0,004]	2.36 [0,268]
NT17-030	30:1	57 [6,4]	52 [5,9]	48 [5,4]	46 [5,2]	170 [19,2]	0.026 [0,003]	2.36 [0,268]
NT17-050	50:1	91 [10,3]	78 [8,8]	65 [7,4]	60 [6,7]	170 [19,2]	0.026 [0,003]	2.36 [0,268]
NT17-100	100:1	40 [4,5]	38 [4,3]	35 [4,0]	33 [3,8]	170 [19,2]	0.026 [0,003]	2.36 [0,268]

<sup>1</sup> Ratios are exact, higher ratios and other custom options are also available, consult factory.  
T<sub>r</sub> = Rated output torque at rated speed for specific hours of life.

T<sub>peak</sub> = Allowable momentary peak torque for emergency stop or heavy shock loading.  
J = Mass moment of inertia reflected to the input shaft (including pinion assembly).

# NemaTRUE™ Size 23/60

## True Planetary Gearheads

English

English - Dimensions are in. (mm)

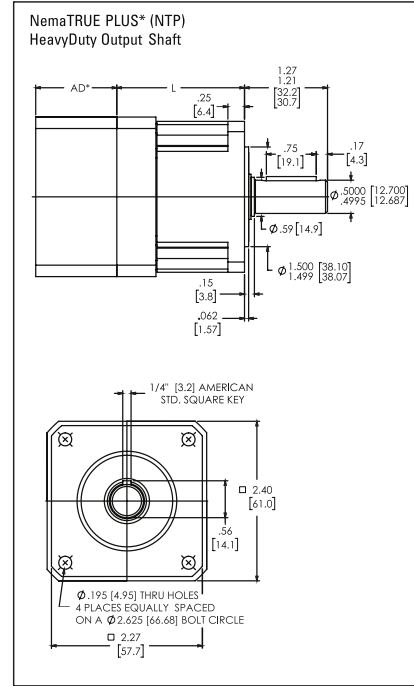
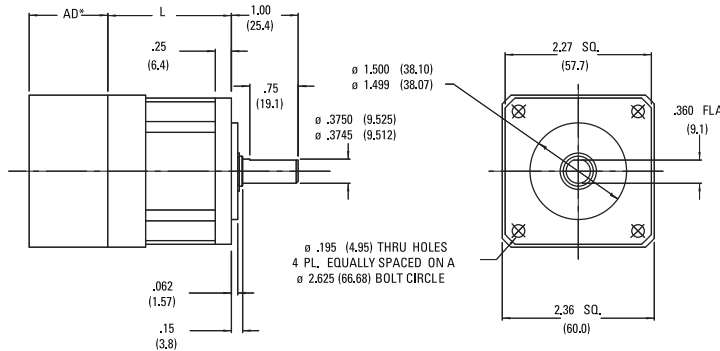

Metric - Dimensions are mm (in)

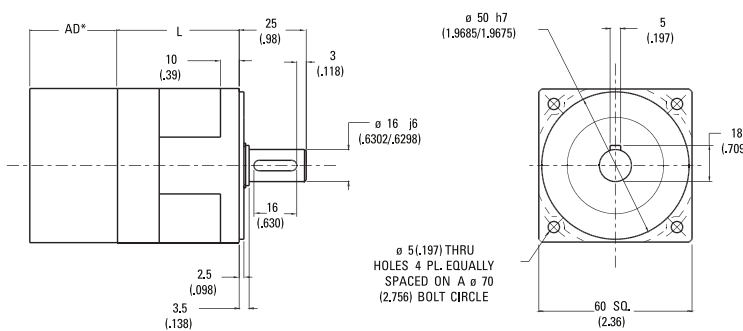

Ratio <sup>1</sup>	NT23	NT60	Backlash [arc-min]		Weight lb. [kg]	Efficiency
	Dimension 'L' in. [mm]	Dimension 'L' in. [mm]	Precision	High Precision		
3:1 to 10:1	1.92 [48,8]	2.07 [52,6]	13 max	8 max	1.5 [0,7]	93%
15:1 to 100:1	2.61 [66,3]	2.76 [70,1]	15 max	9 max	1.9 [0,9]	88%

AD\*\* = Adapter length  
 Adapter length will vary depending on motor.  
 Efficiency is calculated at 100% of the rated torque.

## Performance Specifications

Part Number		Ratio <sup>1</sup>	20000 Hour Life				T <sub>peak</sub> in.-lb. [Nm]	J in.-lb.-sec <sup>2</sup> x10 <sup>-4</sup> [kg-cm <sup>2</sup> ]	Torsional Stiffness in.-lb./arc-min [Nm/arc-min]	
English	Metric		T <sub>r</sub> (1000 rpm) in.-lb. [Nm]	T <sub>r</sub> (2000 rpm) in.-lb. [Nm]	T <sub>r</sub> (3000 rpm) in.-lb. [Nm]	T <sub>r</sub> (4000 rpm) in.-lb. [Nm]			NT	NTP
NT23-003	NT60-003		3:1	98 [11,1]	80 [9,0]	70 [7,9]			65 [7,3]	150 [16,9]
NT23-004	NT60-004	4:1	107 [12,1]	90 [10,2]	80 [9,0]	73 [8,2]	250 [28,3]	0.22 [0,024]	6.3 [0,71] 15.8 [1,8]	
NT23-005	NT60-005	5:1	105 [11,9]	88 [9,9]	78 [8,8]	71 [8,0]	250 [28,2]	0.22 [0,025]	6.3 [0,71] 15.8 [1,8]	
NT23-007	NT60-007	7:1	100 [11,3]	83 [9,4]	74 [8,4]	66 [7,5]	250 [28,3]	0.22 [0,024]	6.3 [0,71] 15.8 [1,8]	
NT23-010	NT60-010	10:1	163 [7,1]	58 [6,6]	54 [6,1]	52 [5,9]	250 [28,2]	0.14 [0,016]	6.3 [0,71] 15.8 [1,8]	
NT23-015	NT60-015	15:1	124 [14,0]	110 [12,4]	105 [11,9]	100 [11,3]	250 [28,3]	0.21 [0,024]	6.3 [0,71] 15.8 [1,8]	
NT23-020	NT60-020	20:1	180 [20,3]	147 [16,6]	130 [14,7]	120 [13,6]	275 [31,1]	0.21 [0,024]	6.3 [0,71] 15.8 [1,8]	
NT23-025	NT60-025	25:1	175 [9,8]	142 [16,0]	125 [14,1]	115 [13,0]	250 [28,3]	0.21 [0,024]	6.3 [0,71] 15.8 [1,8]	
NT23-030	NT60-030	30:1	207 [23,4]	182 [20,6]	157 [17,7]	147 [16,6]	275 [31,1]	0.13 [0,015]	6.3 [0,71] 15.8 [1,8]	
NT23-040	NT60-040	40:1	207 [23,4]	182 [20,6]	157 [17,7]	147 [16,6]	275 [31,1]	0.13 [0,015]	6.3 [0,71] 15.8 [1,8]	
NT23-050	NT60-050	50:1	202 [22,8]	175 [19,8]	152 [17,2]	142 [16,0]	275 [31,1]	0.13 [0,015]	6.3 [0,71] 15.8 [1,8]	
NT23-070	NT60-070	70:1	197 [22,3]	172 [19,4]	147 [16,6]	137 [15,5]	275 [31,1]	0.13 [0,015]	6.3 [0,71] 15.8 [1,8]	
NT23-100	NT60-100	100:1	85 [9,6]	79 [8,9]	74 [8,9]	73 [8,2]	275 [31,1]	0.13 [0,015]	6.3 [0,71] 15.8 [1,8]	

All ratios are available to ship in 24 hours through the Gearhead Express Program.

<sup>1</sup> Ratios are exact, higher ratios and other custom options are also available, consult factory.

T<sub>r</sub> = Rated output torque at rated speed for specific hours of life.

T<sub>peak</sub> = Allowable momentary peak torque for emergency stop or heavy shock loading.  
 J = Mass moment of inertia reflected to the input shaft (including pinion assembly).

# NemaTRUE Size 34/90

## True Planetary Gearheads

English

English - Dimensions are in. (mm)

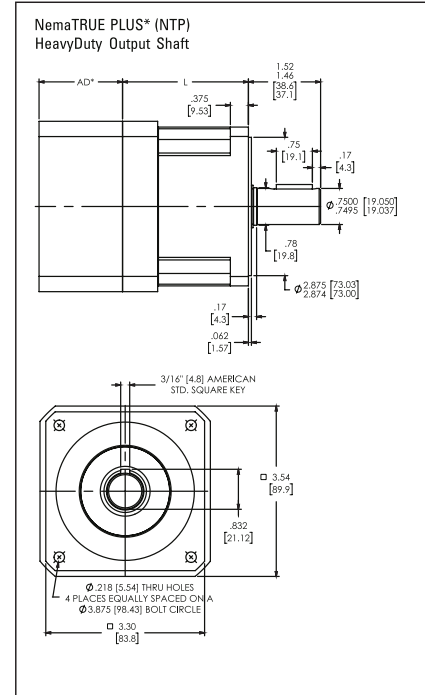
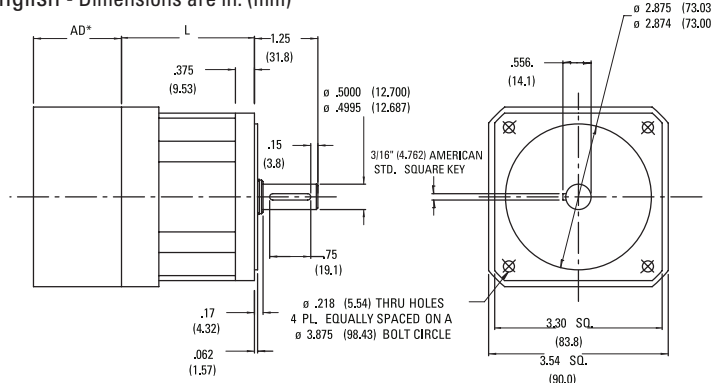

Metric - Dimensions are mm (in)

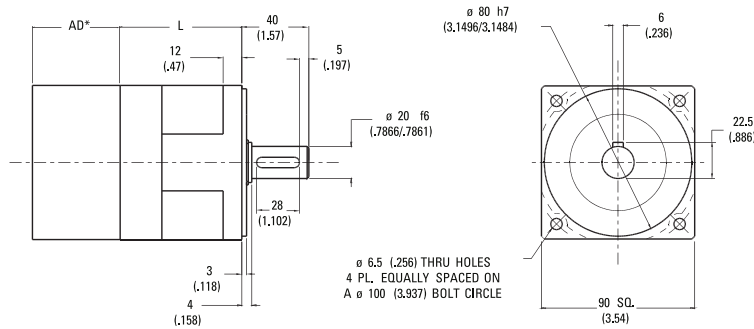

Ratio <sup>1</sup>	NT34	NT90	Backlash [arc-min]		Weight lb. [kg]	Efficiency
	Dimension 'L' in. [mm]	Dimension 'L' in. [mm]	Precision	High Precision		
3:1 to 10:1	2.62 [66,4]	2.63 [66,8]	13 max	8 max	4.2 [1,9]	93%
15:1 to 100:1	3.53 [89,6]	3.53 [89,7]	15 max	9 max	5.6 [2,5]	88%

AD\*\* = Adapter length  
 Adapter length will vary depending on motor.  
 Efficiency is calculated at 100% of the rated torque.

## Performance Specifications

Part Number		Ratio <sup>1</sup>	20000 Hour Life				T <sub>peak</sub> in.-lb. [Nm]	J in.-lb.-sec <sup>2</sup> x 10 <sup>-4</sup> [kg-cm <sup>2</sup> ]	Torsional Stiffness in.-lb./arc-min [Nm/arc-min]	
English	Metric		T <sub>r</sub> (1000 rpm) in.-lb. [Nm]	T <sub>r</sub> (2000 rpm) in.-lb. [Nm]	T <sub>r</sub> (3000 rpm) in.-lb. [Nm]	T <sub>r</sub> (4000 rpm) in.-lb. [Nm]			NT	NTP
NT34-003	NT90-003	3:1	360 [40,7]	320 [36,2]	295 [33,3]	270 [30,5]	510 [57,6]	3.9 [0,44]	16.8 [1,9]	48 [5,4]
NT34-004	NT90-004	4:1	515 [58,2]	425 [48,0]	380 [42,9]	350 [39,6]	700 [79,1]	1.20 [0,140]	16.8 [1,9]	48 [5,4]
NT34-005	NT90-005	5:1	490 [55,4]	400 [45,2]	355 [40,1]	325 [36,7]	700 [79,1]	1.20 [0,140]	16.8 [1,9]	48 [5,4]
NT34-007	NT90-007	7:1	470 [53,1]	380 [42,9]	335 [37,9]	305 [34,5]	700 [79,1]	1.20 [0,140]	16.8 [1,9]	48 [5,4]
NT34-010	NT90-010	10:1	238 [26,9]	212 [24,0]	200 [22,6]	192 [21,7]	700 [79,1]	0.66 [0,075]	16.8 [1,9]	48 [5,4]
NT34-015	NT90-015	15:1	454 [51,3]	416 [47,0]	391 [44,2]	373 [42,1]	850 [96,0]	1.20 [0,140]	16.8 [1,9]	48 [5,4]
NT34-020	NT90-020	20:1	677 [76,5]	620 [70,1]	587 [66,3]	551 [62,3]	850 [96,1]	1.20 [0,140]	16.8 [1,9]	48 [5,4]
NT34-025	NT90-025	25:1	652 [73,7]	595 [67,2]	562 [63,5]	526 [59,4]	850 [96,0]	1.20 [0,140]	16.8 [1,9]	48 [5,4]
NT34-030	NT90-030	30:1	500 [56,5]	454 [51,3]	432 [48,8]	416 [47,0]	850 [96,0]	0.66 [0,075]	16.8 [1,9]	48 [5,4]
NT34-040	NT90-040	40:1	770 [87,0]	702 [79,3]	668 [75,5]	620 [70,1]	850 [96,1]	0.65 [0,074]	16.8 [1,9]	48 [5,4]
NT34-050	NT90-050	50:1	720 [81,4]	652 [73,7]	618 [69,8]	595 [67,2]	850 [96,0]	0.65 [0,074]	16.8 [1,9]	48 [5,4]
NT34-070	NT90-070	70:1	770 [87,0]	702 [79,3]	668 [75,5]	620 [70,1]	850 [96,1]	0.65 [0,074]	16.8 [1,9]	48 [5,4]
NT34-100	NT90-100	100:1	325 [36,7]	295 [33,3]	280 [31,6]	270 [30,5]	700 [79,1]	0.65 [0,074]	16.8 [1,9]	48 [5,4]

All ratios are available to ship in 24 hours through the Gearhead Express Program.

<sup>1</sup> Ratios are exact, higher ratios and other custom options are also available, consult factory.

T<sub>r</sub> = Rated output torque at rated speed for specific hours of life.

T<sub>peak</sub> = Allowable momentary peak torque for emergency stop or heavy shock loading.  
 J = Mass moment of inertia reflected to the input shaft (including pinion assembly).

# NemaTRUE™ Size 42/115

## True Planetary Gearheads

English

English - Dimensions are in. (mm)

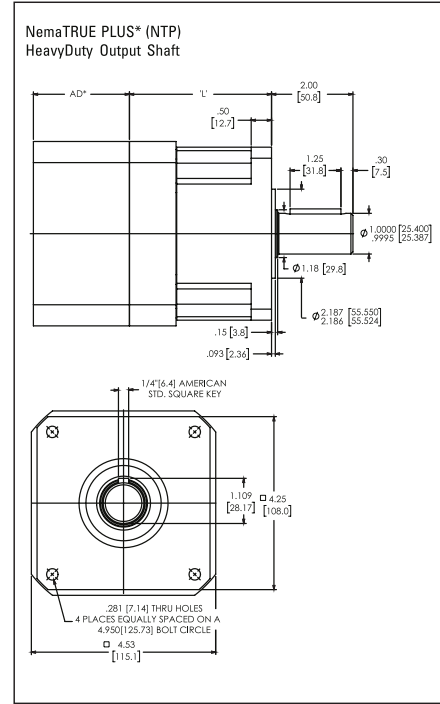
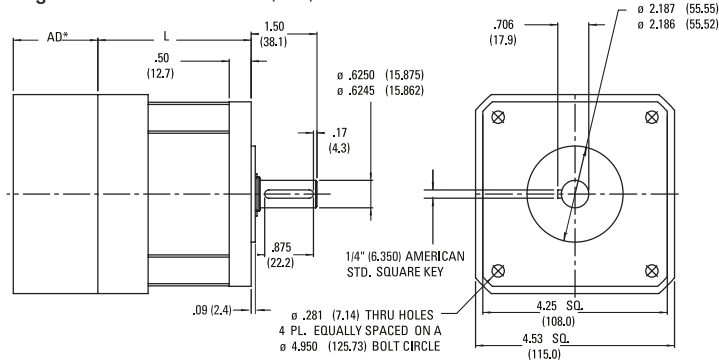

Metric - Dimensions are mm (in)

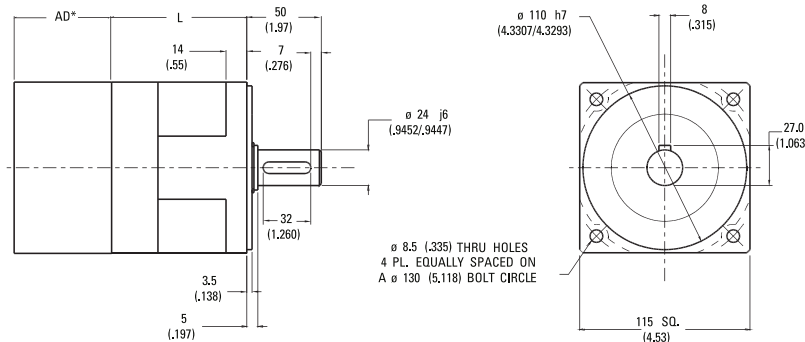

Ratio <sup>1</sup>	NT42	NT115	Backlash [arc-min]		Weight lb. [kg]	Efficiency
	Dimension 'L' in. [mm]	Dimension 'L' in. [mm]	Precision	High Precision		
3:1 to 10:1	3.49 [88,7]	3.46 [87,9]	13 max	8 max	8.9 [4.0]	93%
15:1 to 100:1	4.72 [120,0]	4.69 [119,1]	15 max	9 max	11.7 [5.3]	88%

AD\*\* = Adapter length  
 Adapter length will vary depending on motor.  
 Efficiency is calculated at 100% of the rated torque.

## Performance Specifications

Part Number		Ratio <sup>1</sup>	20000 Hour Life				T <sub>peak</sub> in.-lb. [Nm]	J in.-lb.-sec <sup>2</sup> x10 <sup>-4</sup> [kg-cm <sup>2</sup> ]	Torsional Stiffness in.-lb./arc-min [Nm/arc-min]	
English	Metric		T <sub>r</sub> (1000 rpm) in.-lb. [Nm]	T <sub>r</sub> (2000 rpm) in.-lb. [Nm]	T <sub>r</sub> (3000 rpm) in.-lb. [Nm]	T <sub>r</sub> (4000 rpm) in.-lb. [Nm]			NT	NTP
NT42-003	NT115-003		3:1	690 [78.0]	594 [67.1]	530 [59.9]			485 [54.8]	1000 [113.0]
NT42-004	NT115-004	4:1	850 [96.1]	698 [78.9]	622 [70.3]	570 [64.4]	1000 [113.0]	3.80 [0.43]	31 [3.5]	154 [17.4]
NT42-005	NT115-005	5:1	810 [55.4]	400 [45.2]	355 [40.1]	325 [36.7]	1000 [113.0]	3.80 [0.43]	31 [3.5]	154 [17.4]
NT42-007	NT115-007	7:1	790 [89.3]	638 [72.1]	562 [63.5]	510 [57.6]	1000 [113.0]	3.80 [0.43]	31 [3.5]	154 [17.4]
NT42-010	NT115-010	10:1	460 [52.0]	412 [46.6]	388 [43.8]	370 [41.8]	1000 [113.0]	1.9 [0.21]	31 [3.5]	154 [17.4]
NT42-015	NT115-015	15:1	454 [51.3]	416 [47.0]	391 [44.2]	373 [42.1]	1600 [180.8]	3.9 [0.44]	31 [3.5]	154 [17.4]
NT42-020	NT115-020	20:1	1290 [145.8]	1090 [123.2]	985 [111.3]	905 [102.3]	1600 [180.8]	3.70 [0.42]	31 [3.5]	154 [17.4]
NT42-025	NT115-025	25:1	1250 [141.2]	1050 [118.6]	945 [106.8]	865 [97.7]	1600 [180.8]	3.70 [0.42]	31 [3.5]	154 [17.4]
NT42-030	NT115-030	30:1	972 [109.8]	878 [99.2]	842 [95.1]	805 [91.0]	1600 [180.8]	1.9 [0.21]	31 [3.5]	154 [17.4]
NT42-040	NT115-040	40:1	1435 [162.2]	1290 [145.8]	1190 [134.5]	1090 [123.2]	1600 [180.8]	1.80 [0.20]	31 [3.5]	154 [17.4]
NT42-050	NT115-050	50:1	1395 [157.6]	1250 [141.2]	1150 [118.6]	1050 [118.6]	1600 [180.8]	1.80 [0.20]	31 [3.5]	154 [17.4]
NT42-070	NT115-070	70:1	1375 [155.4]	1230 [139.0]	1130 [127.7]	1030 [116.4]	1600 [180.8]	1.80 [0.20]	31 [3.5]	154 [17.4]
NT42-100	NT115-100	100:1	630 [71.2]	575 [65.0]	540 [61.0]	522 [59.0]	1200 [135.6]	1.80 [0.20]	31 [3.5]	154 [17.4]

All ratios are available to ship in 24 hours through the Gearhead Express Program.

<sup>1</sup> Ratios are exact, higher ratios and other custom options are also available, consult factory.

T<sub>r</sub> = Rated output torque at rated speed for specific hours of life.

T<sub>peak</sub> = Allowable momentary peak torque for emergency stop or heavy shock loading.  
 J = Mass moment of inertia reflected to the input shaft (including pinion assembly).

# Radial and Axial Load Ratings

## NT17

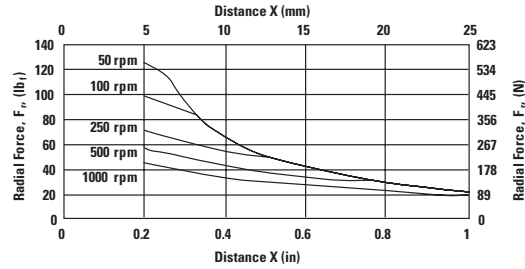
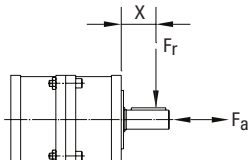

Speed rpm	Axial Load, $F_a$ lb <sub>f</sub> [N]
250	138 [614]

## NT23, NTP23, NT60

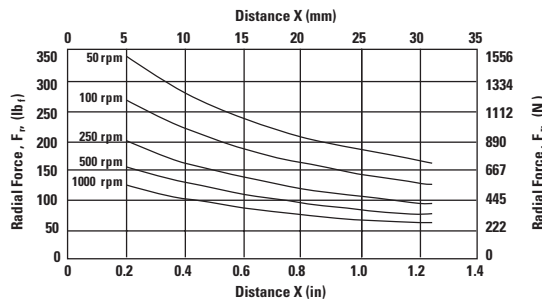
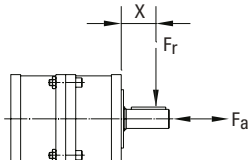

Speed rpm	Axial Load, $F_a$ lb <sub>f</sub> [N]
250	310 [1379]

## NT34, NTP34, NT90

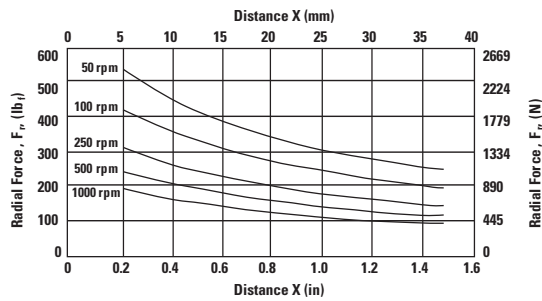
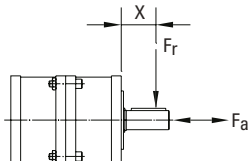

Speed rpm	Axial Load, $F_a$ lb <sub>f</sub> [N]
250	510 [2269]

## NT42, NTP42, NT115

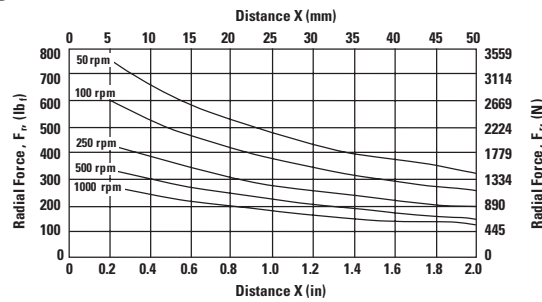
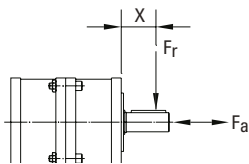

Speed rpm	Axial Load, $F_a$ lb <sub>f</sub> [N]
250	760 [3380]

These graphs display the allowable radial load at a given distance (X) from the mounting surface based on an L<sub>10</sub> life of 10,000 hours for the mean output speed  $n_{mout}$ , as described on page 9.

# NemaTRUE™ 90

## Right Angle Gearheads

Ready for Immediate Delivery	
Precision	13 arc-minutes
Frame Sizes	NEMA 23, 34, 42
Torque Capacity	up to 255 Nm
Ratio Availability	1:1 thru 500:1
Radial load capacity	up to 2900 N
Mounting System	RediMount™

- 1 Tapered roller bearings**  
provide high radial and axial load capacity
- 2 Innovative PowerTRUE gearing**  
delivers smooth, quiet geared reduction
- 3 Tapered roller bearings**  
provide high axial load carrying capabilities
- 4 HRC 55-60 steel gears**  
provide superior wear resistance and increased backlash integrity
- 5 RediMount system**  
provides error-free motor installation

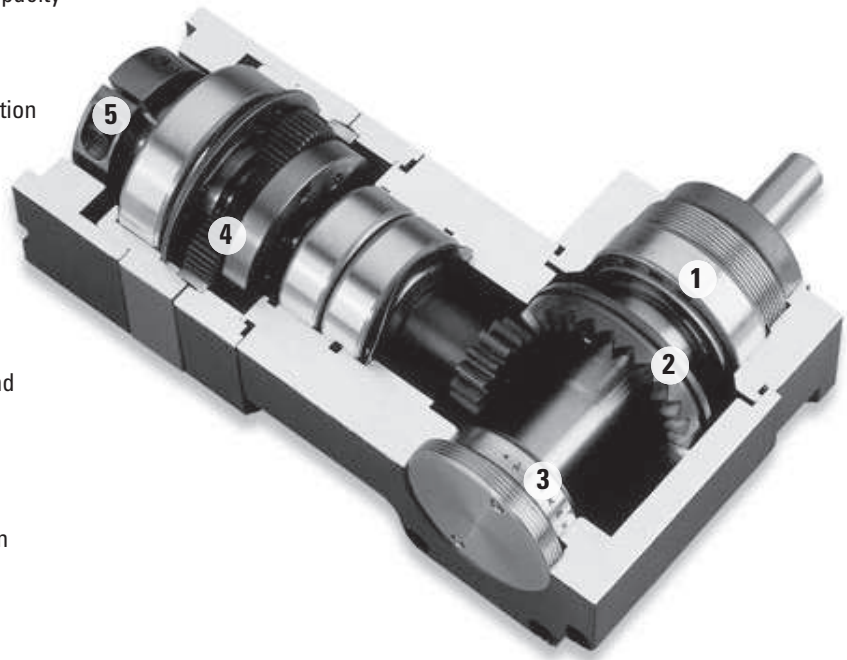

# NemaTRUE 90 Size 23

## Right Angle Gearheads

English

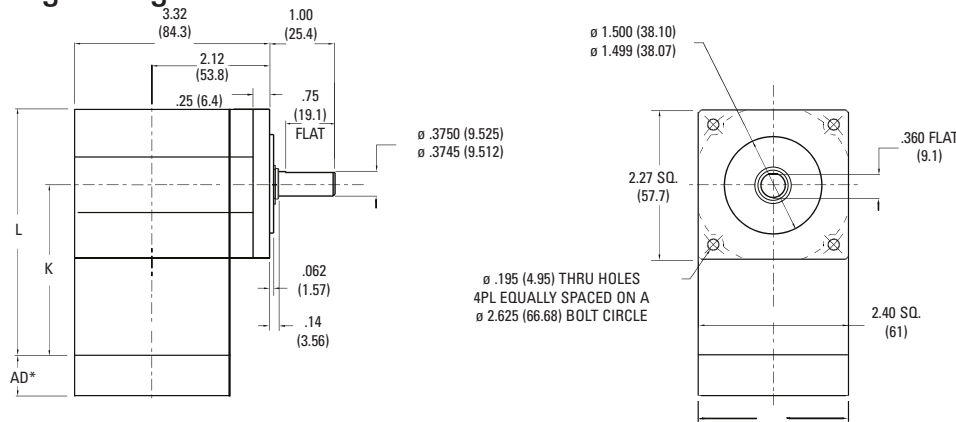

Ratio <sup>1</sup>	Dimension 'K' in. [mm]	Dimension 'L' in. [mm]	Backlash [arc-min]	Weight lb. [kg]	Efficiency
1:1 to 5:1P	3.11 [79]	4.31 [109,5]	13 max	3.0 [1,4]	98%
5:1T to 50:1	3.79 [96]	4.99 [127]	15 max	3.4 [1,5]	93%
60:1 to 500:1	4.48 [114]	5.68 [144]	15 max	3.8 [1,6]	88%

Dimensions are in. (mm)  
AD\*\* = Adapter length  
Adapter length will vary depending on motor.  
Efficiency is calculated at 100% of the rated torque.

## Performance Specifications

Part Number	Ratio <sup>1</sup>	10000 Hour Life			T <sub>peak</sub> in.-lb. [Nm]	20000 Hour Life			J in.-lb.-sec <sup>2</sup> × 10 <sup>-4</sup> [kg-cm <sup>2</sup> ]	Torsional Stiffness in.-lb./arc-min [Nm/arc-min]
		T <sub>r</sub> (1000 rpm) in.-lb. [Nm]	T <sub>r</sub> (3000 rpm) in.-lb. [Nm]	T <sub>r</sub> (5000 rpm) in.-lb. [Nm]		T <sub>r</sub> (1000 rpm) in.-lb. [Nm]	T <sub>r</sub> (3000 rpm) in.-lb. [Nm]	T <sub>r</sub> (5000 rpm) in.-lb. [Nm]		
NTR23-001	1:1	59 [7]	54 [6]	49 [6]	195 [22]	54 [6]	50 [6]	45 [5]	7.01 [0,79]	5.6 [0,6]
NTR23-002	2:1	130 [15]	118 [13]	107 [12]	360 [41]	120 [14]	109 [12]	99 [11]	3.59 [0,41]	8.5 [1,0]
NTR23-003	3:1	83 [9]	75 [9]	68 [8]	270 [31]	76 [9]	70 [8]	63 [7]	3.09 [0,35]	9.6 [1,1]
NTR23-004	4:1	61 [7]	56 [6]	50 [6]	238 [27]	56 [6]	51 [6]	46 [5]	2.87 [0,32]	10.1 [1,1]
NTR23-005P	5:1P	50 [6]	46 [5]	41 [5]	180 [20]	46 [5]	42 [5]	38 [4]	2.81 [0,32]	10.3 [1,2]
NTR23-005T	5:1T	179 [20]	153 [17]	138 [16]	366 [41]	175 [20]	132 [15]	112 [13]	3.69 [0,42]	10.3 [1,2]
NTR23-006	6:1	153 [17]	130 [15]	126 [14]	366 [41]	149 [17]	120 [14]	116 [13]	3.67 [0,41]	6.7 [0,8]
NTR23-009	9:1	97 [11]	83 [9]	80 [9]	289 [33]	95 [11]	76 [9]	74 [8]	3.08 [0,35]	8.5 [1,0]
NTR23-010	10:1	157 [18]	144 [16]	130 [15]	366 [41]	155 [18]	138 [16]	120 [14]	3.48 [0,39]	6.6 [0,7]
NTR23-012	12:1	72 [8]	61 [7]	59 [7]	252 [28]	70 [8]	56 [6]	55 [6]	2.95 [0,33]	9.3 [1,1]
NTR23-015	15:1	100 [11]	91 [10]	83 [9]	297 [34]	99 [11]	88 [10]	76 [9]	2.89 [0,33]	9.8 [1,1]
NTR23-020	20:1	74 [8]	67 [8]	61 [7]	366 [41]	73 [8]	64 [7]	56 [6]	2.76 [0,31]	9.3 [1,0]
NTR23-025	25:1	60 [7]	55 [6]	50 [6]	198 [22]	60 [7]	53 [6]	46 [5]	2.71 [0,31]	9.8 [1,1]
NTR23-030	30:1	102 [12]	98 [11]	94 [11]	305 [34]	102 [11]	96 [11]	90 [10]	2.83 [0,32]	8.0 [0,9]
NTR23-040	40:1	75 [9]	72 [8]	69 [8]	263 [30]	75 [8]	71 [8]	67 [8]	2.69 [0,30]	9.0 [1,0]
NTR23-050	50:1	62 [7]	59 [7]	57 [6]	203 [23]	61 [7]	58 [7]	55 [6]	2.64 [0,30]	9.6 [1,1]
NTR23-060	60:1	163 [18]	161 [18]	158 [18]	366 [41]	163 [18]	160 [18]	157 [18]	3.68 [0,42]	6.5 [0,7]
NTR23-075	75:1	104 [12]	102 [12]	100 [11]	311 [35]	103 [12]	101 [11]	99 [11]	2.95 [0,33]	8.4 [0,9]
NTR23-090	90:1	104 [12]	102 [12]	101 [11]	313 [35]	103 [12]	102 [11]	100 [11]	3.09 [0,35]	8.3 [0,9]
NTR23-100	100:1	163 [18]	162 [18]	161 [18]	366 [41]	163 [18]	161 [18]	160 [18]	3.50 [0,40]	6.5 [0,7]
NTR23-120	120:1	76 [9]	75 [9]	74 [8]	270 [31]	76 [9]	75 [8]	73 [8]	2.96 [0,33]	9.2 [1,0]
NTR23-125	125:1	63 [7]	62 [7]	60 [7]	207 [23]	62 [7]	61 [7]	60 [7]	2.76 [0,31]	9.7 [1,1]
NTR23-150	150:1	104 [12]	103 [12]	102 [12]	316 [36]	104 [12]	103 [12]	102 [11]	2.91 [0,33]	8.4 [0,9]
NTR23-200	200:1	164 [19]	163 [18]	162 [18]	366 [41]	164 [18]	163 [18]	162 [18]	3.43 [0,39]	6.1 [0,7]
NTR23-250	250:1	63 [7]	62 [7]	62 [7]	207 [23]	63 [7]	62 [7]	61 [7]	2.72 [0,31]	9.7 [1,1]
NTR23-300	300:1	104 [12]	104 [12]	103 [12]	319 [36]	104 [12]	104 [12]	103 [12]	2.84 [0,32]	8.0 [0,9]
NTR23-400	400:1	77 [9]	76 [9]	76 [9]	274 [31]	77 [9]	76 [9]	76 [9]	2.71 [0,31]	9.0 [1,0]
NTR23-500	500:1	63 [7]	63 [7]	62 [7]	207 [23]	63 [7]	63 [7]	62 [7]	2.66 [0,30]	9.6 [1,1]

Ratio 5P is designed using only PowerTRUE face gearing technology.

Ratio 5T adds a True Planetary gearing stage for increased torque capacity.

<sup>1</sup> Ratios are exact, higher ratios and other custom options are also available, consult factory.

T<sub>r</sub> = Rated output torque at rated speed for specific hours of life.

J = Mass moment of inertia reflected to the input shaft (including pinion assembly)

T<sub>peak</sub> = Allowable momentary peak torque for emergency stop or heavy shock loading.



# NemaTRUE™ 90 Size 34

## Right Angle Gearheads

English

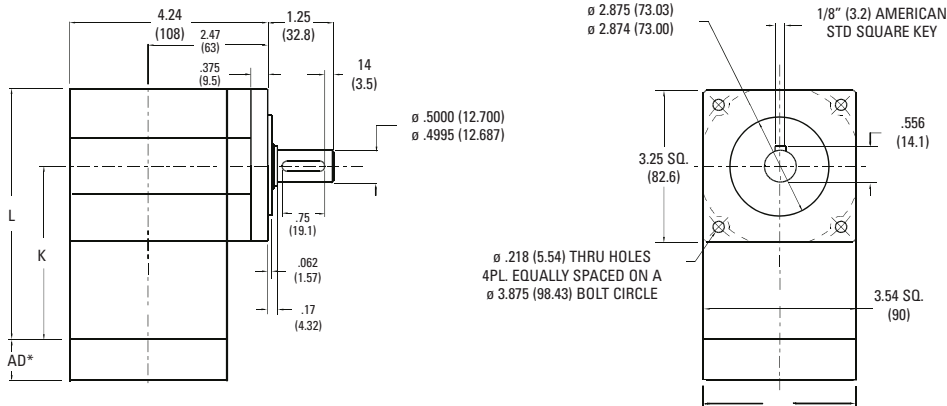

Ratio <sup>1</sup>	Dimension 'K' in. [mm]	Dimension 'L' in. [mm]	Backlash [arc-min]	Weight lb. [kg]	Efficiency
1:1 to 5:1P	3.99 [101]	5.76 [146]	13 max	6.0 [2,7]	98%
5:1T to 50:1	4.89 [124]	6.66 [169]	15 max	7.4 [3,4]	93%
60:1 to 500:1	5.79 [147]	7.56 [192]	15 max	8.8 [4,0]	88%

Dimensions are in. (mm)  
AD\*\* = Adapter length  
Adapter length will vary depending on motor.  
Efficiency is calculated at 100% of the rated torque.

## Performance Specifications

Part Number	Ratio <sup>1</sup>	10000 Hour Life			T <sub>peak</sub> in.-lb. [Nm]	20000 Hour Life			J in.-lb.-sec <sup>2</sup> × 10 <sup>-4</sup> [kg-cm <sup>2</sup> ]	Torsional Stiffness in.-lb./arc-min [Nm/arc-min]
		T <sub>r</sub> (1000 rpm) in.-lb. [Nm]	T <sub>r</sub> (3000 rpm) in.-lb. [Nm]	T <sub>r</sub> (5000 rpm) in.-lb. [Nm]		T <sub>r</sub> (1000 rpm) in.-lb. [Nm]	T <sub>r</sub> (3000 rpm) in.-lb. [Nm]	T <sub>r</sub> (5000 rpm) in.-lb. [Nm]		
NTR34-001	1:1	168 [19]	153 [17]	139 [16]	493 [56]	155 [18]	142 [16]	128 [14]	27.5 [3,11]	12.6 [1,4]
NTR34-002	2:1	381 [43]	348 [39]	315 [36]	1113 [126]	352 [40]	321 [36]	291 [33]	14.1 [1,59]	19.1 [2,2]
NTR34-003	3:1	251 [28]	229 [26]	207 [23]	905 [102]	232 [26]	212 [24]	192 [22]	12.1 [1,37]	21.5 [2,4]
NTR34-004	4:1	192 [22]	176 [20]	159 [18]	695 [79]	178 [20]	162 [18]	147 [17]	11.2 [1,27]	22.6 [2,5]
NTR34-005P	5:1P	142 [16]	129 [15]	117 [13]	581 [66]	131 [15]	119 [13]	108 [12]	11.0 [1,25]	23.1 [2,6]
NTR34-005T	5:1T	508 [57]	432 [49]	420 [47]	1113 [126]	497 [56]	399 [45]	387 [44]	14.5 [1,64]	23.1 [2,6]
NTR34-006	6:1	448 [51]	381 [43]	370 [42]	1113 [126]	439 [50]	352 [40]	342 [39]	14.4 [1,63]	15.0 [1,7]
NTR34-009	9:1	296 [33]	251 [28]	244 [28]	986 [111]	289 [33]	232 [26]	225 [25]	12.1 [1,37]	19.0 [2,1]
NTR34-010	10:1	462 [52]	422 [48]	381 [43]	1113 [126]	456 [52]	404 [46]	352 [40]	13.7 [1,54]	14.8 [1,7]
NTR34-012	12:1	226 [26]	192 [22]	187 [21]	752 [85]	221 [25]	178 [20]	173 [19]	11.6 [1,31]	20.9 [2,4]
NTR34-015	15:1	305 [34]	278 [31]	251 [28]	1018 [115]	301 [34]	266 [30]	232 [26]	11.3 [1,28]	21.9 [2,5]
NTR34-020	20:1	233 [26]	213 [24]	192 [22]	1113 [126]	230 [26]	204 [23]	178 [20]	10.8 [1,22]	20.8 [2,4]
NTR34-025	25:1	172 [19]	157 [18]	142 [16]	635 [72]	169 [19]	150 [17]	131 [15]	10.6 [1,20]	21.9 [2,5]
NTR34-030	30:1	311 [35]	298 [34]	285 [32]	1045 [118]	309 [35]	292 [33]	275 [31]	11.1 [1,25]	17.9 [2,0]
NTR34-040	40:1	238 [27]	228 [26]	218 [25]	792 [89]	237 [27]	224 [25]	210 [24]	10.6 [1,19]	20.2 [2,3]
NTR34-050	50:1	175 [20]	168 [19]	160 [18]	653 [74]	174 [20]	165 [19]	155 [18]	10.4 [1,17]	21.4 [2,4]
NTR34-060	60:1	479 [54]	472 [53]	465 [53]	1113 [126]	478 [54]	469 [53]	460 [52]	14.4 [1,63]	14.5 [1,6]
NTR34-075	75:1	315 [36]	310 [35]	305 [34]	1080 [122]	314 [36]	308 [35]	301 [34]	11.6 [1,31]	18.7 [2,1]
NTR34-090	90:1	316 [36]	311 [35]	307 [35]	1085 [123]	315 [36]	309 [35]	304 [34]	12.1 [1,37]	18.6 [2,1]
NTR34-100	100:1	480 [54]	476 [54]	472 [53]	1113 [126]	479 [54]	474 [54]	469 [53]	13.7 [1,55]	14.6 [1,7]
NTR34-120	120:1	242 [27]	238 [27]	235 [27]	817 [92]	241 [27]	237 [27]	232 [26]	11.6 [1,31]	20.7 [2,3]
NTR34-125	125:1	178 [20]	175 [20]	172 [19]	666 [75]	177 [20]	173 [20]	169 [19]	10.8 [1,23]	21.8 [2,5]
NTR34-150	150:1	317 [36]	314 [35]	311 [35]	1096 [124]	316 [36]	313 [35]	309 [35]	11.4 [1,29]	18.7 [2,1]
NTR34-200	200:1	481 [54]	479 [54]	477 [54]	1113 [126]	481 [54]	478 [54]	475 [54]	13.5 [1,52]	13.6 [1,5]
NTR34-250	250:1	178 [20]	177 [20]	175 [20]	675 [76]	178 [20]	176 [20]	174 [20]	10.7 [1,21]	21.8 [2,5]
NTR34-300	300:1	317 [36]	316 [36]	315 [36]	1107 [125]	317 [36]	315 [36]	314 [35]	11.1 [1,26]	17.9 [2,0]
NTR34-400	400:1	243 [27]	242 [27]	241 [27]	832 [94]	243 [27]	241 [27]	240 [27]	10.6 [1,20]	20.2 [2,3]
NTR34-500	500:1	179 [20]	178 [20]	177 [20]	680 [77]	179 [20]	178 [20]	177 [20]	10.4 [1,18]	21.4 [2,4]

Ratio 5P is designed using only PowerTRUE face gearing technology.

Ratio 5T adds a True Planetary gearing stage for increased torque capacity.

<sup>1</sup> Ratios are exact, higher ratios and other custom options are also available, consult factory.

T<sub>r</sub> = Rated output torque at rated speed for specific hours of life.

J = Mass moment of inertia reflected to the input shaft (including pinion assembly)

T<sub>peak</sub> = Allowable momentary peak torque for emergency stop or heavy shock loading.

# NemaTRUE™ 90 Size 42

## Right Angle Gearheads

English

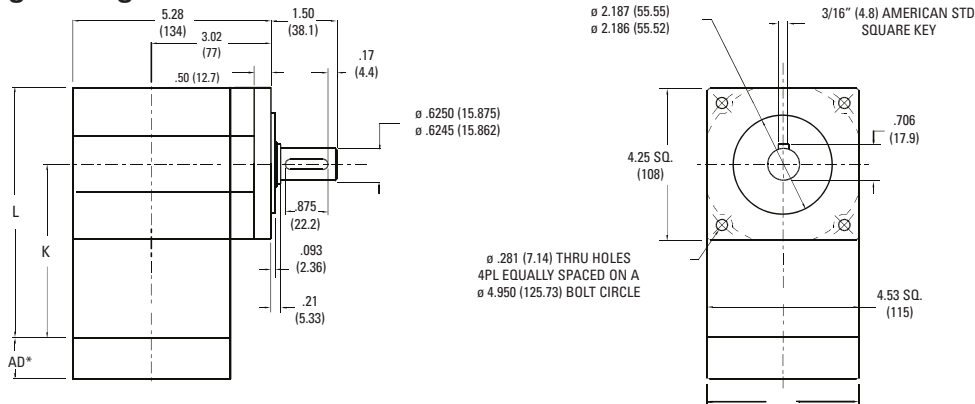

Ratio <sup>1</sup>	Dimension 'K' in [mm]	Dimension 'L' in [mm]	Backlash [arc-min]	Weight lb [kg]	Efficiency
1:1 to 5:1P	5.40 [137]	7.67 [195]	13 max	12 [5,4]	98%
5:1T to 50:1	6.63 [168,4]	8.90 [226]	15 max	14.8 [6,7]	93%
60:1 to 500:1	7.87 [200]	10.13 [257]	15 max	17.6 [8,0]	88%

Dimensions are inch (mm)  
AD\*\* = Adapter length  
Adapter length will vary depending on motor.  
Efficiency is calculated at 100% of the rated torque.

## Performance Specifications

Part Number	Ratio <sup>1</sup>	10000 Hour Life			T <sub>peak</sub> in-lb [Nm]	20000 Hour Life			J in-lb-sec <sup>2</sup> × 10 <sup>-4</sup> [kg-cm <sup>2</sup> ]	Torsional Stiffness in-lb/arc-min [Nm/arc-min]
		T <sub>r</sub> (1000 rpm) in-lb [Nm]	T <sub>r</sub> (3000 rpm) in-lb [Nm]	T <sub>r</sub> (5000 rpm) in-lb [Nm]		T <sub>r</sub> (1000 rpm) in-lb [Nm]	T <sub>r</sub> (3000 rpm) in-lb [Nm]	T <sub>r</sub> (5000 rpm) in-lb [Nm]		
NTR42-001	1:1	496 [56]	452 [51]	409 [46]	1620 [183]	458 [52]	418 [47]	378 [43]	46.7 [5,28]	15.0 [1,7]
NTR42-002	2:1	885 [100]	808 [91]	730 [83]	2255 [255]	817 [92]	746 [84]	674 [76]	23.9 [2,71]	24.7 [2,8]
NTR42-003	3:1	687 [78]	627 [71]	567 [64]	2039 [230]	635 [72]	579 [65]	524 [59]	20.6 [2,33]	28.0 [3,2]
NTR42-004	4:1	458 [52]	418 [47]	378 [43]	1584 [179]	423 [48]	386 [44]	349 [39]	19.1 [2,16]	29.4 [3,3]
NTR42-005P	5:1P	343 [39]	313 [35]	283 [32]	1305 [147]	317 [36]	289 [33]	261 [30]	18.8 [2,12]	30.0 [3,4]
NTR42-005T	5:1T	1346 [152]	1117 [126]	958 [108]	2255 [255]	1262 [143]	907 [102]	778 [88]	24.6 [2,78]	30.0 [3,4]
NTR42-006	6:1	1041 [118]	885 [100]	859 [97]	2255 [255]	1018 [115]	817 [92]	794 [90]	24.5 [2,77]	20.1 [2,3]
NTR42-009	9:1	808 [91]	687 [78]	667 [75]	2241 [253]	791 [89]	635 [72]	616 [70]	20.5 [2,32]	25.1 [2,8]
NTR42-010	10:1	1072 [121]	979 [111]	885 [100]	2255 [255]	1059 [120]	938 [106]	817 [92]	23.2 [2,63]	20.1 [2,3]
NTR42-012	12:1	538 [61]	458 [52]	444 [50]	1728 [195]	526 [59]	423 [48]	410 [46]	19.6 [2,22]	27.5 [3,1]
NTR42-015	15:1	832 [94]	760 [86]	687 [78]	2255 [255]	822 [93]	728 [82]	635 [72]	19.3 [2,18]	28.8 [3,3]
NTR42-020	20:1	554 [63]	506 [57]	458 [52]	2255 [255]	547 [62]	485 [55]	423 [48]	18.4 [2,08]	27.5 [3,1]
NTR42-025	25:1	416 [47]	379 [43]	343 [39]	1458 [165]	410 [46]	364 [41]	317 [36]	18.0 [2,04]	28.8 [3,2]
NTR42-030	30:1	851 [96]	814 [92]	778 [88]	2255 [255]	845 [96]	798 [90]	752 [85]	18.9 [2,13]	24.6 [2,8]
NTR42-040	40:1	566 [64]	542 [61]	518 [59]	1836 [207]	563 [64]	532 [60]	500 [57]	18.0 [2,03]	27.2 [3,1]
NTR42-050	50:1	425 [48]	407 [46]	388 [44]	1499 [169]	422 [48]	399 [45]	375 [42]	17.6 [1,99]	28.5 [3,2]
NTR42-060	60:1	1111 [126]	1095 [124]	1080 [122]	2255 [255]	1109 [125]	1089 [123]	1069 [121]	24.6 [2,78]	19.7 [2,2]
NTR42-075	75:1	861 [97]	847 [96]	832 [94]	2255 [255]	859 [97]	841 [95]	822 [93]	19.7 [2,22]	25.0 [2,8]
NTR42-090	90:1	863 [97]	851 [96]	838 [95]	2255 [255]	861 [97]	845 [96]	830 [94]	20.6 [2,33]	24.8 [2,8]
NTR42-100	100:1	1114 [126]	1105 [125]	1095 [124]	2255 [255]	1113 [126]	1101 [124]	1089 [123]	23.3 [2,64]	19.9 [2,2]
NTR42-120	120:1	574 [65]	566 [64]	558 [63]	1897 [214]	573 [65]	563 [64]	552 [62]	19.7 [2,23]	27.3 [3,1]
NTR42-125	125:1	430 [49]	423 [48]	416 [47]	1539 [174]	429 [48]	420 [47]	410 [46]	18.4 [2,08]	28.7 [3,2]
NTR42-150	150:1	865 [98]	858 [97]	851 [96]	2255 [255]	864 [98]	855 [97]	845 [96]	19.4 [2,19]	25.0 [2,8]
NTR42-200	200:1	1116 [126]	1112 [126]	1107 [125]	2255 [255]	1116 [126]	1110 [125]	1104 [125]	22.9 [2,59]	19.4 [2,2]
NTR42-250	250:1	432 [49]	428 [48]	425 [48]	1562 [176]	431 [49]	427 [48]	422 [48]	18.1 [2,05]	28.7 [3,2]
NTR42-300	300:1	867 [98]	863 [98]	860 [97]	2255 [255]	866 [98]	862 [97]	857 [97]	18.9 [2,14]	24.6 [2,8]
NTR42-400	400:1	577 [65]	575 [65]	572 [65]	1944 [220]	577 [65]	574 [65]	571 [64]	18.1 [2,04]	27.1 [3,1]
NTR42-500	500:1	433 [49]	431 [49]	429 [48]	1580 [178]	433 [49]	430 [49]	428 [48]	17.7 [2,00]	28.5 [3,2]

Ratio 5P is designed using only PowerTRUE face gearing technology.  
Ratio 5T adds a True Planetary gearing stage for increased torque capacity.  
<sup>1</sup> Ratios are exact, higher ratios and other custom options are also available, consult factory.

T<sub>r</sub> = Rated output torque at rated speed for specific hours of life.  
J = Mass moment of inertia reflected to the input shaft (including pinion assembly)  
T<sub>peak</sub> = Allowable momentary peak torque for emergency stop or heavy shock loading.

# Radial and Axial Load Ratings

## NTR23

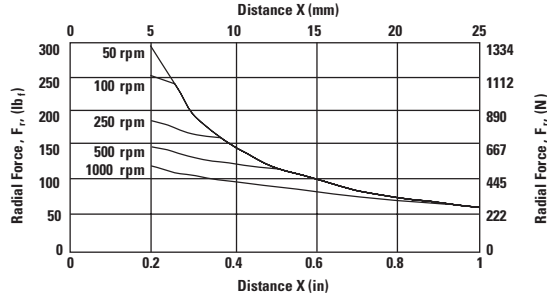
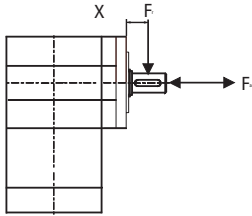

Speed rpm	Axial Load, $F_a$ $l_b_f$ [N]
50	250 [1110]
100	200 [890]
250	150 [670]
500	120 [530]
1000	90 [400]

## NTR34

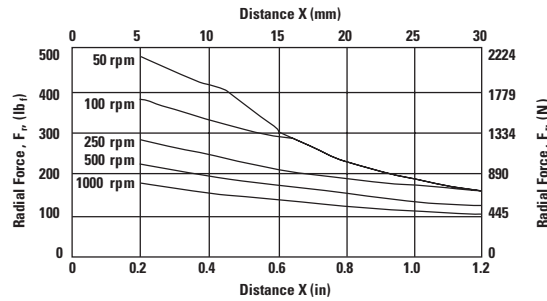
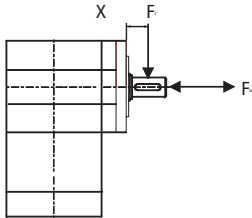

Speed rpm	Axial Load, $F_a$ $l_b_f$ [N]
50	340 [1510]
100	270 [1200]
250	200 [890]
500	160 [710]
1000	130 [580]

## NTR42

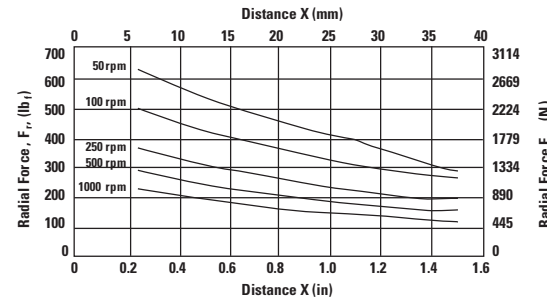
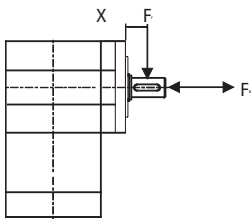

Speed rpm	Axial Load, $F_a$ $l_b_f$ [N]
50	460 [2050]
100	370 [1650]
250	270 [1200]
500	210 [930]
1000	170 [760]

These graphs display the allowable radial load at a given distance (X) from the mounting surface based on an  $L_{10}$  life of 10,000 hours for the mean output speed  $n_{mout}$ , as described on page 9.

# Gearhead Ordering Information

Visit [www.micronmotioneering.com](http://www.micronmotioneering.com) to get your complete RediMount part number using your motor manufacturer and model number information.

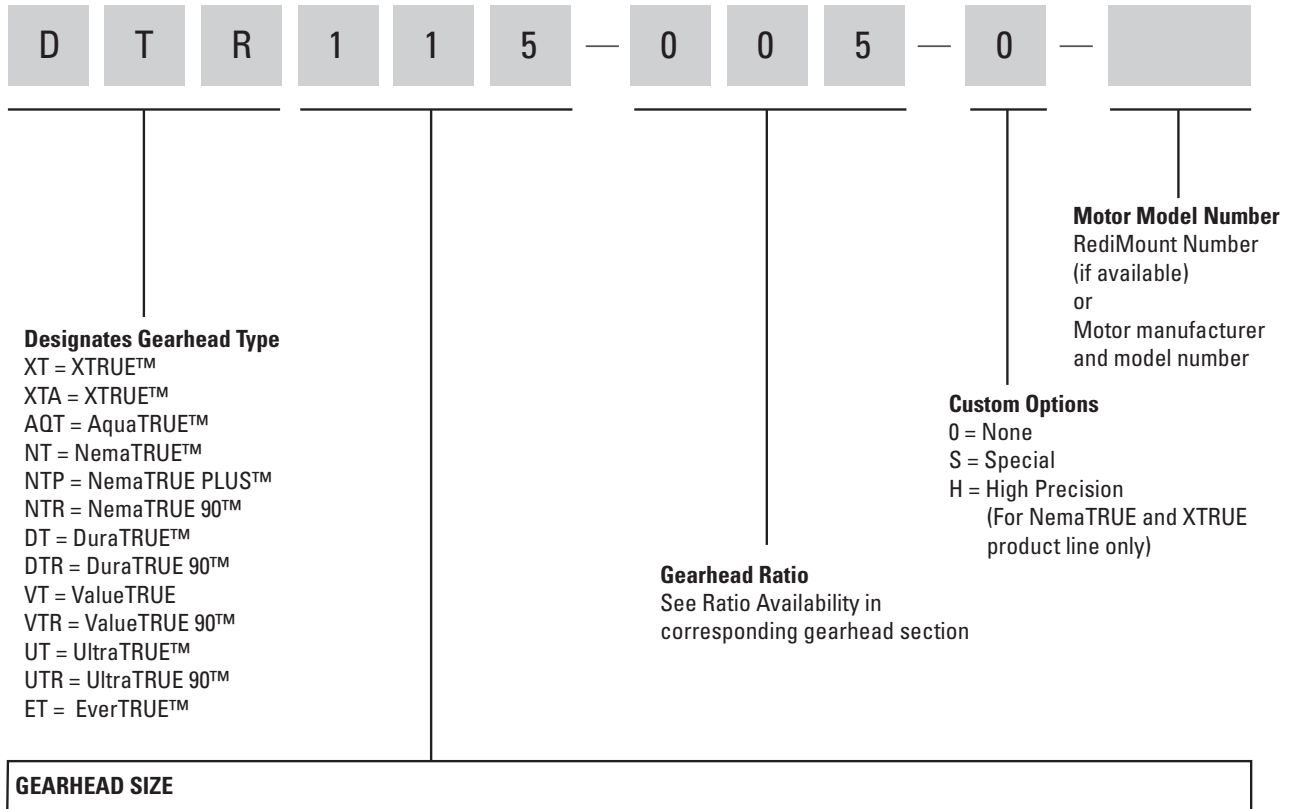

<b>XTRUE XT AquaTRUE</b>	<b>NemaTRUE NemaTRUE PLUS NemaTRUE 90</b>	<b>DuraTRUE DuraTRUE 90 DuraTRUE (Hollow Shaft) DuraTRUE (Dual Shaft)</b>	<b>UltraTRUE UltraTRUE 90</b>	<b>EverTRUE</b>	<b>ValueTRUE ValueTRUE 90</b>
040 = 40 mm	17 = Size 17	60 = Size 60	006 = Size 60	10 = Size 10	006 = Size 60
060 = 60 mm	23 = Size 23	90 = Size 90	075 = Size 75	14 = Size 14	075 = Size 75
080 = 80 mm	34 = Size 34	115 = Size 115	090 = Size 90	18 = Size 18	090 = Size 90
120 = 120 mm	42 = Size 42	142 = Size 142	010 = Size 10		010 = Size 10
160 = 160 mm	60 = Size 60		115 = Size 115		115 = Size 115
	90 = Size 90		014 = Size 14		014 = Size 14
<b>XTRUE XTA</b>	115 = Size 115		018 = Size 18		018 = Size 18
050 = 50 mm			022 = Size 22 (UltraTRUE only)		022 = Size 22
070 = 70 mm					
090 = 90 mm					
120 = 120 mm					